

# Panasonic®

## Operating Instructions

---

HD Analog Board

Model No. **AV-HSB300G**

ENGLISH

DEUTSCH

FRANÇAIS

ITALIANO

ESPAÑOL

РУССКИЙ

日本語

Before operating this product, please read the instructions carefully and save this manual for future use.

## ENGLISH VERSION

### Safety precautions



#### CAUTION

**RISK OF ELECTRIC SHOCK  
DO NOT OPEN**



CAUTION: TO REDUCE THE RISK OF ELECTRIC SHOCK,  
DO NOT REMOVE COVER (OR BACK).  
NO USER SERVICEABLE PARTS INSIDE.  
REFER TO SERVICING TO QUALIFIED SERVICE PERSONNEL.



The lightning flash with arrowhead symbol, within an equilateral triangle, is intended to alert the user to the presence of uninsulated "dangerous voltage" within the product's enclosure that may be of sufficient magnitude to constitute a risk of electric shock to persons.



The exclamation point within an equilateral triangle is intended to alert the user to the presence of important operating and maintenance (service) instructions in the literature accompanying the appliance.

#### WARNING:

- TO REDUCE THE RISK OF FIRE OR ELECTRIC SHOCK, DO NOT EXPOSE THIS APPARATUS TO RAIN OR MOISTURE.
- THE APPARATUS SHALL NOT BE EXPOSED TO DRIPPING OR SPLASHING AND THAT NO OBJECTS FILLED WITH LIQUIDS, SUCH AS VASES, SHALL BE PLACED ON THE APPARATUS.

#### CAUTION:

TO REDUCE THE RISK OF FIRE OR SHOCK HAZARD AND ANNOYING INTERFERENCE, USE THE RECOMMENDED ACCESSORIES ONLY.

#### CAUTION:

TO REDUCE THE RISK OF FIRE OR SHOCK HAZARD, REFER CHANGES OF SWITCH SETTINGS INSIDE THE UNIT TO QUALIFIED SERVICE PERSONNEL.

For CANADA

**This class A digital apparatus complies with Canadian ICES-003.**

**Cet appareil numérique de la classe A est conforme à la norme NMB-003 du Canada.**

#### FCC Note:

This equipment has been tested and found to comply with the limits for a class A digital device, pursuant to Part 15 of the FCC Rules. These limits are designed to provide reasonable protection against harmful interference when the equipment is operated in a commercial environment. This equipment generates, uses, and can radiate radio frequency energy, and if not installed and used in accordance with the instruction manual, may cause harmful interference to radio communications. Operation of this equipment in a residential area is likely to cause harmful interference in which case the user will be required to correct the interference at his own expense.

#### Warning:

To assure continued FCC emission limit compliance, the user must use only shielded interface cables when connecting to external units. Also, any unauthorized changes or modifications to this equipment could void the user's authority to operate it.

 indicates safety information.

## IMPORTANT SAFETY INSTRUCTIONS

Read these operating instructions carefully before using the unit. Follow the safety instructions on the unit and the applicable safety instructions listed below. Keep these operating instructions handy for future reference.

- 1) Read these instructions.
- 2) Keep these instructions.
- 3) Heed all warnings.
- 4) Follow all instructions.
- 5) Do not use this apparatus near water.
- 6) Clean only with dry cloth.
- 7) Do not block any ventilation openings. Install in accordance with the manufacturer's instructions.
- 8) Do not install near any heat sources such as radiators, heat registers, stoves, or other apparatus (including amplifiers) that produce heat.
- 9) Do not defeat the safety purpose of the polarized or grounding-type plug. A polarized plug has two blades with one wider than the other. A grounding-type plug has two blades and a third grounding prong. The wide blade or the third prong are provided for your safety. If the provided plug does not fit into your outlet, consult an electrician for replacement of the obsolete outlet.
- 10) Protect the power cord from being walked on or pinched particularly at plugs, convenience receptacles, and the point where they exit from the apparatus.
- 11) Only use attachments/accessories specified by the manufacturer.
- 12) Use only with the cart, stand, tripod, bracket, or table specified by the manufacturer, or sold with the apparatus. When a cart is used, use caution when moving the cart/apparatus combination to avoid injury from tip-over. 
- 13) Unplug this apparatus during lightning storms or when unused for long periods of time.
- 14) Refer all servicing to qualified service personnel. Servicing is required when the apparatus has been damaged in any way, such as power-supply cord or plug is damaged, liquid has been spilled or objects have fallen into the apparatus, the apparatus has been exposed to rain or moisture, does not operate normally, or has been dropped.

 indicates safety information.

# Safety precautions

---

## Information on Disposal for Users of Waste Electrical & Electronic Equipment (private households)



This symbol on the products and/or accompanying documents means that used electrical and electronic products should not be mixed with general household waste. For proper treatment, recovery and recycling, please take these products to designated collection points, where they will be accepted on a free of charge basis. Alternatively, in some countries you may be able to return your products to your local retailer upon the purchase of an equivalent new product.

Disposing of this product correctly will help to save valuable resources and prevent any potential negative effects on human health and the environment which could otherwise arise from inappropriate waste handling. Please contact your local authority for further details of your nearest designated collection point. Penalties may be applicable for incorrect disposal of this waste, in accordance with national legislation.

### For business users in the European Union

If you wish to discard electrical and electronic equipment, please contact your dealer or supplier for further information.

### Information on Disposal in other Countries outside the European Union

This symbol is only valid in the European Union. If you wish to discard this product, please contact your local authorities or dealer and ask for the correct method of disposal.

## Contents

---

Safety precautions .....	1	Mounting .....	4
Introduction .....	3	Connections .....	7
Accessory .....	3	Appearance .....	8
Name of each part .....	4	Specifications .....	8

## Introduction

---

Installing this HD analog board in a multi-format live switcher AV-HS300G makes it possible to support five HD analog component inputs. The signal formats support HD formats (1080/59.94i, 1080/50i, 720/59.94p, 720/50p).

## Accessory

---

Operating instructions .....	1
------------------------------	---

## Name of each part

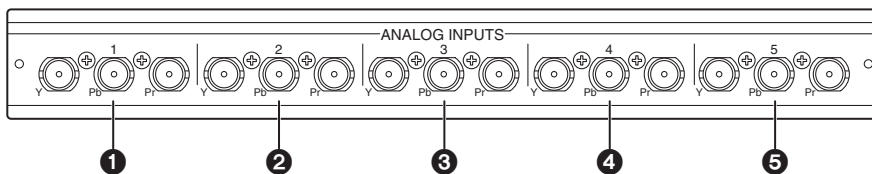

① to ⑤: Analog HD component input connectors [ANALOG INPUTS 1 to 5]

## Mounting

Install this board in the multi-format live switcher AV-HS300G.

### <NOTES>

- Be sure to ask the store or dealer where you purchased the product for assistance with mounting and removal.
- Set to OFF and unplug the power connector before mounting and removal.
- Before handling the HD analog board, touch a metal part of the AV-HS300G to discharge the static electricity from the human body.  
An anti-static wrist strap is recommended for safety. Failures may be caused if you touch the HD analog board while you are still charged with static electricity.
- Keep the metal parts of the HD analog board free of contact with other metal parts.
- Be sure to mount the blank panel installed with the AV-HS300G, after removing the HD analog board.

① Turn off the power of the AV-HS300G, and unplug the power connector.

② Remove the 6 screws (A).

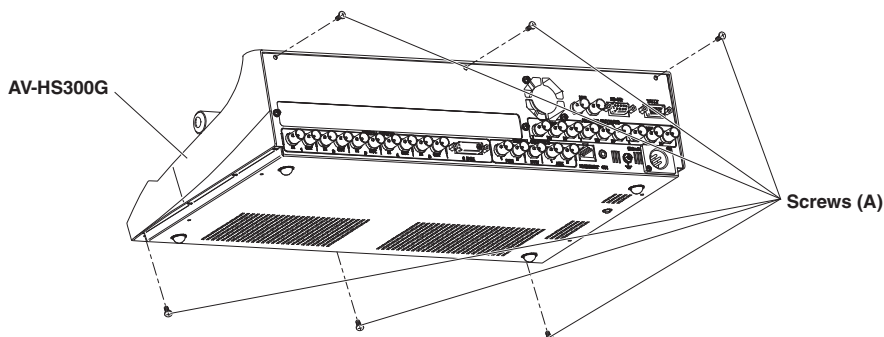

# Mounting

- ③ Remove the upper panel cover.

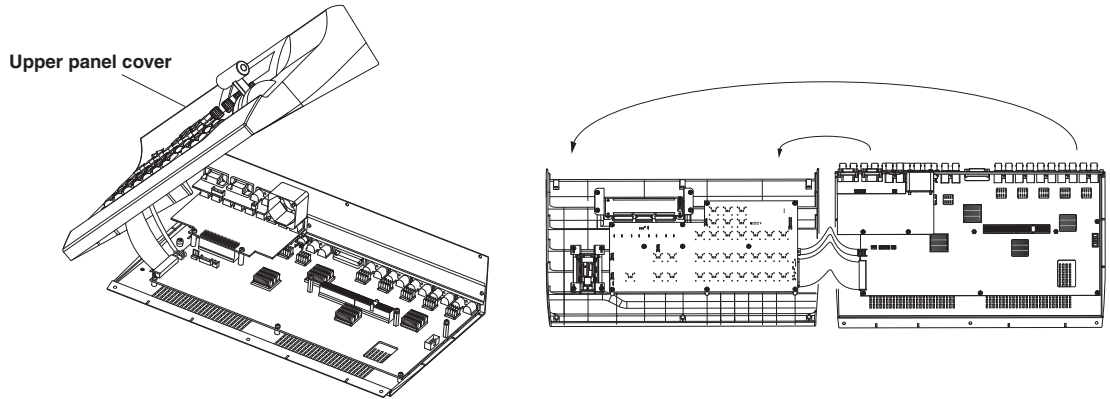

- ④ Remove the 2 screws (B), and remove the blank panel.

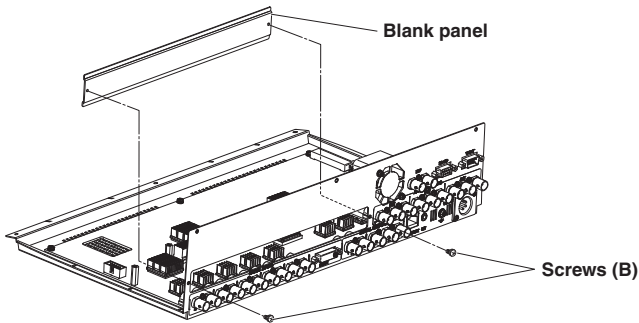

- ⑤ Remove the 3 screws (C) and 1 cable clamp.

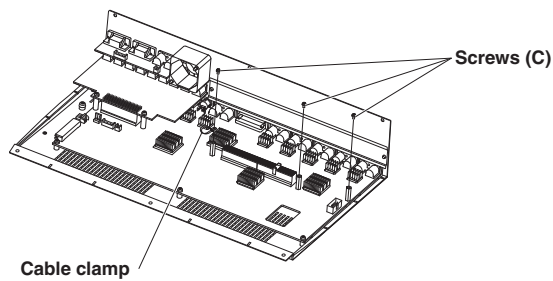

- ⑥ Insert the HD analog board from the inside of the rear panel, and insert it along the guide rail for the connector. (Insert it securely and completely.)

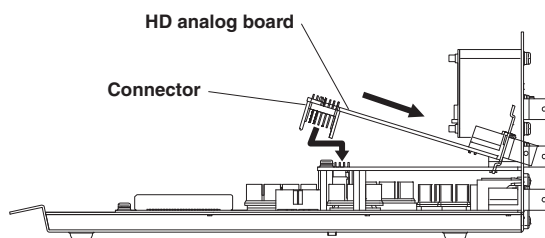

# Mounting

- ⑦ Install the board securely using the 2 screws (B) and 3 screws (C).  
(At this stage, install the cable clamp as well.)

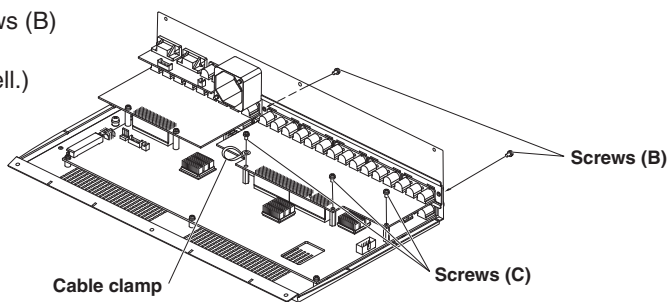

- ⑧ Tighten the 6 screws (A) for the upper panel cover securely.

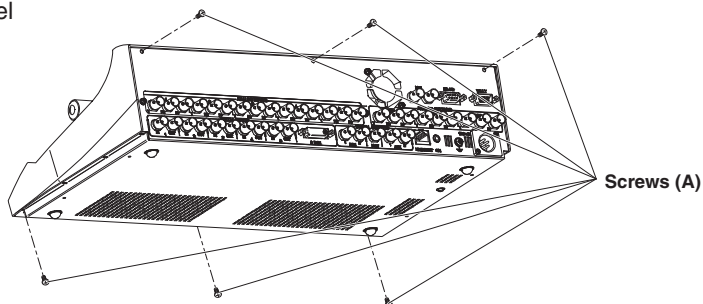

- ⑨ After attaching the required cables, insert the power connector and turn the power on.

For details on the setting and operating procedures, refer to the operating instructions of the AV-HS300G. If the HD analog board has been connected properly, “ANLG” will appear at the OPT item on the AV-HS300G’s SETUP/STATS menu (15/15).

STATS	ALM	OPT	VER
15/15	NO	ANLG	1.00

In order for the analog HD component signals to take effect, select “ANLG” (analog HD component) in the MODE item setting for each of the input channels (IN1 to IN5) from the AV-HS300G’s SETUP/IN1-5 menu (1/15). Analog HD component signals and SDI signals cannot be used at the same time in the same input channel.

Additionally, the gain of the input signals is set using the GAIN item. (The gain can be set within the  $\pm 30$ -step range, and the setting will result in changes of  $\pm 2$  dB. The amount by which the gain changes per step is not the same for each step.)

IN1-5	SIG	MODE	GAIN
1/15	IN1	ANLG	-30-30

IN2	SDI	-
IN3		
IN4		
IN5		

## Removal procedure

Remove the HD analog board by following the procedures for mounting it in reverse.

# Connections

- Make the connection with the HD analog board while the power is off.
- For details on connecting individual devices, refer to the respective operating instructions.
- For details on operating individual devices, refer to the respective operating instructions.

## Connections when gen-lock is not implemented (frame synchronizer ON)

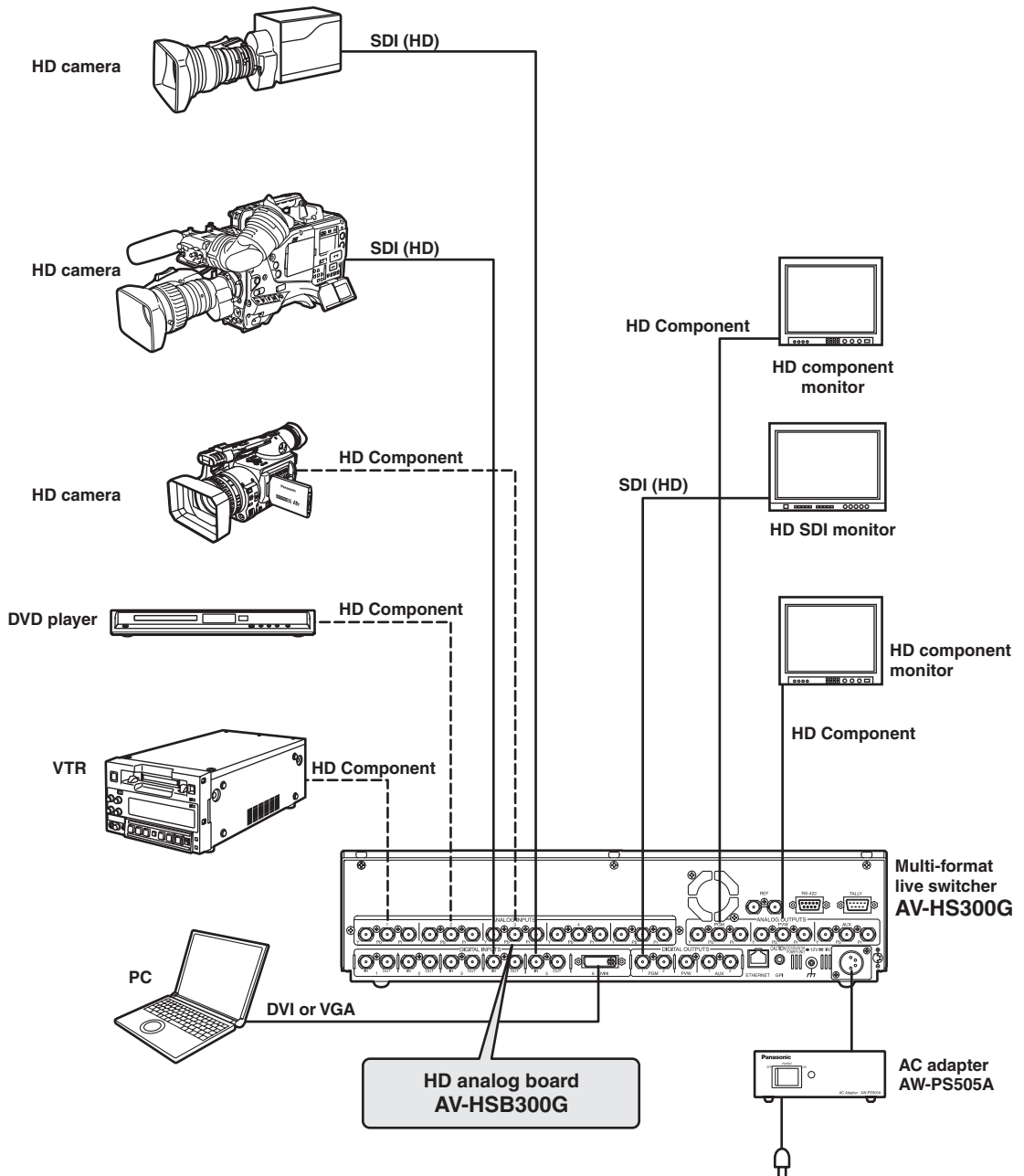



# Panasonic<sup>®</sup>

**PANASONIC BROADCAST & TELEVISION SYSTEMS COMPANY**  
UNIT COMPANY OF PANASONIC CORPORATION OF NORTH AMERICA

**Headquarters:**

3 Panasonic Way 4E-7, Secaucus, NJ 07094 (201) 348-5300

**EASTERN ZONE:**

3 Panasonic Way 4E-7, Secaucus, NJ 07094 (201) 348-7196

**WESTERN ZONE:**

3330 Cahuenga Blvd. West, Los Angeles, CA 90068 (323) 438-3608

**Government office:**

(201) 348-7587

**Broadcast PARTS INFORMATION & ORDERING:**

9:00 a.m. – 5:00 p.m. (PST) (800) 334-4881/24 Hr. Fax (800) 334-4880

Emergency after hour parts orders (800) 334-4881

**TECHNICAL SUPPORT:**

Emergency 24 Hour Service (800) 222-0741

**Panasonic Canada Inc.**

5770 Ambler Drive, Mississauga, Ontario L4W 2T3 (905) 624-5010

**Panasonic de Mexico S.A. de C.V.**

Av angel Urreza Num. 1209 Col. de Valle 03100 Mexico, D.F. (52) 1 951 2127

**Panasonic Puerto Rico Inc.**

San Gabriel Industrial Park, 65th Infantry Ave., Km. 9.5, Carolina, Puerto Rico 00630 (787) 750-4300

© 2006 Matsushita Electric Industrial Co., Ltd. All rights reserved.

---

## Matsushita Electric Industrial Co., Ltd.

Web Site: <http://panasonic.net>

---

## 松下電器産業株式会社 ブロードメディア本部

〒223-8639 横浜市港北区綱島東4丁目3番1号  フリーダイヤル 0120-878-410

© 2006 Matsushita Electric Industrial Co., Ltd. (松下電器産業株式会社) All Rights Reserved.

Printed in Japan  
Gedruckt in Japan  
Imprimé au Japon  
Stampato in Giappone  
Impreso en Japón  
Напечатано в Японии

VQTB0155-1

F1206S2037 